



**Strand**

# CANTATA LED FRESNEL TUNABLE COLD WHITE

USER MANUAL

# 1 DESCRIPTION

## FEATURES

---

- High output midsize LED Fresnel
- Tunable Cold White Version with Consistent High CRI
- High CRI RGBALC Color System with SmartColor Control
- Tunable white with >94 CRI
- Independent color mixing and temperature controls
- Standard-size accessory rails to support optional 8 leaf barn door or third-party accessories
- Quiet operation with variable fan control (Standard, Studio, and Whisper)
- Adjustable frequency to exceed camera frame rates

Download the product datasheet from the Strand website at [www.strandlighting.com](http://www.strandlighting.com) for the full technical specifications.

## COMPONENTS

---

The document provides installation and operation instructions for the following products:

- Strand Cantata LED Fresnel Tunable Cold White

Read all instructions before installing or using this product. Retain this manual for future reference. Additional product information and descriptions may be found on the product specification sheet.

## INCLUDED ITEMS

Each Strand Cantata LED Fresnel luminaire includes the following items:

- Strand Cantata LED Fresnel Tunable Cold White
- Quick Start Guide

# 2 INSTALLATION

## MOUNTING

The unit should be mounted via its screw holes on the bracket. Always ensure that the unit is firmly fixed to avoid vibration and slipping while operating. Always ensure that the structure to which you are attaching the unit is secure and is able to support a weight of 10 times of the unit's weight. Always use a safety cable that can hold up to 12 times the weight of the unit when installing the fixture.

The luminaire must be mounted by professionals.

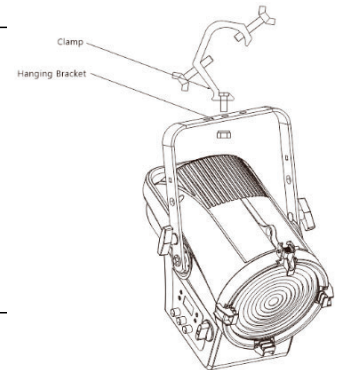

## SET UP

### CONTROL PANEL

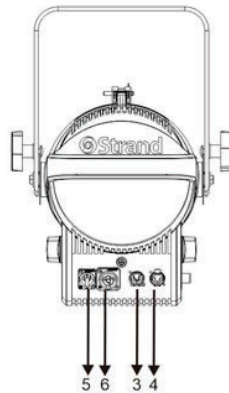
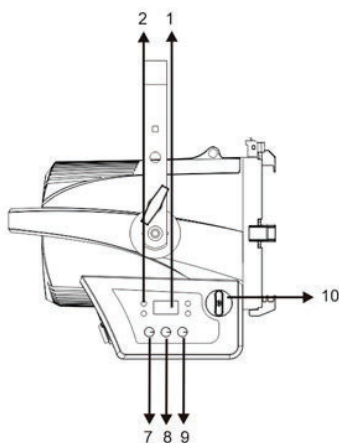

- ① LCD display - shows the menu and selected functions
- ② Buttons:  
MENU - To select the programming functions  
DOWN - To go backward in the selected functions  
UP - To go forward in the selected functions  
ENTER - To confirm the selected functions
- ③ DMX IN - 5-pin XLR cable to link DMX console
- ④ DMX OUT - 5-pin XLR cable to link to the next unit
- ⑤ DMX In - connects to power supply
- ⑥ Power Out - connects to next fixture
- ⑦ DIM from 0-100%
- ⑧ CCT from 4000K to 6500K
- ⑨ N/A
- ⑩ Manual Zoom Knob

### MAIN FUNCTIONS

To select any functions, press the MENU button until the required one is shown on the display. Select the function by the ENTER button and the display will blink. Use the DOWN and UP button to change the mode. Once the required mode has been selected, press the ENTER button to setup or it will automatically return to the main functions without any change after idling one minute. Back to the functions without any change press the MENU button. The main functions are shown in [TABLE 1](#).

TABLE 1. MENU FUNCTIONS

LEVEL 1	LEVEL 2	LEVEL 3	LEVEL 4	LEVEL 5	LEVEL 6	DEFAULT		
Address	001-512	(Default 001)						
Configure	LED	LED Hours	XXXXXX h					
		Reset LED Hour	Are you sure?					
		Dimming Curve	Square Curve				(Default)	
			S Curve					
			Linear Curve					
		Tungsten Fade	On					
			Off				(Default)	
		Dim Snap	On (Fast)					
			Off (Slow)				(Default)	
		LED Frequency	1200Hz				(Default)	
			2500Hz					
			5000Hz					
			10000Hz					
			20000Hz					
			25000Hz					
		White Balance	Red		125 - 255			Default 255
			Green		125 - 255			Default 255
			Blue		125 - 255			Default 255
			Amber		125 - 255			Default 255
			Lime		125 - 255			Default 255
			Cyan		125 - 255			Default 255
			Reset		YES/NO			
		Color Cal	On					
			Off					(Default)
		Disp Timeout	30 Sec					(Default)
			5 Min					
			10 Min					
On								
Select Signal	DMX Only							
	Art-Net							
	SACN							
Set Artnet/ SACN	Set Universe	000-255				(Default 000)		
	Ethernet IP	XXX. XXX. XXX. XXX						
	Ether Mask IP	XXX. XXX. XXX. XXX						

TABLE 1. MENU FUNCTIONS

LEVEL 1	LEVEL 2	LEVEL 3	LEVEL 4	LEVEL 5	LEVEL 6	DEFAULT
DMX	Address	001-512				
	DMX Mode	SSCC				(Default)
		SQCC				
		SOCC				
	Pixel Group	Group 1				(Default)
		Group 3				
		Group 12				
	Cell Direction	Normal				(Default)
		Flipped				
	Data	Ch 1 - Intensity XXX (Value)				
Ch 2 - Intensity Fine XXX (Value)						
.....All functions						
Fixture	Serial Number	Serial Number electronic format				
	Status	(No Errors... or displays a list of errors)				
	Reboot Fixture	Are you sure?				
	Version	VXXX		MM/D/YY	HH:MM	
	Fixture Hours	XXXXXX h				
	Crossload (Software)	Send				
	Service	Diagnostics	Board Check			
Sensor Check						
Manual Control	Red	0 - 255			(Default 0)	
	Green	0 - 255			(Default 0)	
	Blue	0 - 255			(Default 0)	
	Amber	0 - 255			(Default 0)	
	Lime	0 - 255			(Default 0)	
	Cyan	0 - 255			(Default 0)	
Color Preset	Preset Run	Select preset		1 to 20		
		Intensity		0 - 255		
	Edit Programs				Intensity*	0 - 255
					Red	0 - 255
					Green	0 - 255
					Blue	0 - 255
					Amber	0 - 255
					Lime	0 - 255
					Cyan	0 - 255
					Store	YES/NO
			Clear	YES/NO		

## ADDRESS MENU

**Address** — DMX address setting. To select DMX Address, press the ENTER button to confirm. Use the UP/DOWN button to adjust the address from 001 to 512, press the ENTER button to store. Press the MENU button back to the last menu or let the unit idle one minute to exit menu mode.

## CONFIGURE MENU

To select Configure, press the ENTER button to confirm, use the UP/DOWN button to select LED, Color Cal, Disp Timeout, Select Signal and Set Artnet / SACN.

### LED

To select LED, press the ENTER button to confirm. Use the UP/DOWN button to select LED Hours, Reset LED Hour, Dimming Curve, Tungsten Fade, Dim Snap, LED Frequency and White Balance. Press the ENTER button to store. Press the MENU button back to the last menu or let the unit idle one minute to exit menu mode.

**LED Hours** — Select LED Hours, press the ENTER button to confirm, LED Hours will show on the display, press the MENU button back to exit.

**Reset LED Hours** — Select Reset LED Hours, press the ENTER button to confirm, “Are you sure” will show on the display, press the MENU button back to exit.

**Dimming Curve** — To select Dimming Curve, press the ENTER button to confirm. Use the UP/DOWN button to select Square Law Curve, S Law Curve or Linear Law Curve, press the ENTER button to store. Press the MENU button back to the last menu or let the unit idle one minute to exit menu mode.

**Tungsten Fade** — Select Tungsten Fade, press the ENTER button to confirm, Use the UP/DOWN button to select ON or OFF, press the MENU button back to exit.

**Dim Snap** — Select Dim Snap, press the ENTER button to confirm, Use the UP/DOWN button to select ON or OFF, press the MENU button back to exit.

**LED Frequency** — To select LED Frequency, press the ENTER button to confirm. Use the UP/DOWN button to select 1200Hz, 2500Hz, 5000Hz, 10000Hz, 20000Hz, 25000Hz, press the ENTER button to store. Press the MENU button back to the last menu or let the unit idle one minute to exit menu mode.

**White Balance** — To select White Balance, press the ENTER button to confirm. Use the UP/DOWN button to select Red, Green, Blue, Amber, Lime, Cyan and RESET, press the ENTER button to store. Press the MENU button back to the last menu or let the unit idle one minute to exit menu mode.

### Color Cal

To select Color Cal, press the ENTER button to confirm. Use the UP/DOWN button to select ON or OFF, press the MENU button back to exit.

### Disp Timeout

To select Disp Timeout, press the ENTER button to confirm. Use the UP/DOWN button to select 30 Sec, 5min, 10 min or ON, press the MENU button back to exit.

### Select Signal

To select Select Signal, press the ENTER button to confirm. Use the UP/DOWN button to select DMX Only, Artnet or SACN, press the MENU button back to exit.

## DMX MENU

To select DMX, press the ENTER button to confirm, use the UP/DOWN button to select Address, DMX Mode, Pixel Group, Cell Direction or Data.

**Address** — To select Address, press the ENTER button to confirm. Use the UP/DOWN button to select from 001 to 512. press the ENTER button to store. Press the MENU button back to the last menu or let the unit idle one minute to exit menu mode.

**DMX Mode** — To select DMX Mode, press the ENTER button to confirm. Use the UP/DOWN button to select SSCC, SQCC or SOCC, press the ENTER button to store. Press the MENU button back to the last menu or let the unit idle one minute to exit menu mode.

**Pixel Group** — To select Pixel Group, press the ENTER button to confirm. Use the UP/DOWN button to select Group 1 or Group 4, press the ENTER button to store. Press the MENU button back to the last menu or let the unit idle one minute to exit menu mode.

**Cell Direction** — To select Cell Direction, press the ENTER button to confirm. Use the UP/DOWN button to select Normal or Flipped, press the ENTER button to store. Press the MENU button back to the last menu or let the

unit idle one minute to exit menu mode.

**Data —** To select Data, press the ENTER button to confirm. Use the UP/DOWN button to select Ch1 – Intensity xxx(value), Ch2 – Intensity Fine xxx(Value), .... All functions, press the ENTER button to store. Press the MENU button back to the last menu or let the unit idle one minute to exit menu mode.

## FIXTURE MENU

To select Fixture, press the ENTER button to confirm, use the UP/DOWN button to select Status, Reboot fixture, Version, Fixture Hours, Crossload (Software) , Service.

### Status

Select Status, press the ENTER button to confirm, Status will show on the display, press the MENU button back to exit.

### Reboot Fixture

Select Reboot Fixture, press the ENTER button to confirm, Are you sure? will show on the display, press the ENTER button to store. Press the MENU button back to the last menu or let the unit idle one minute to exit menu mode.

### Version

Select Version, press the ENTER button to confirm, Version will show on the display, press the MENU button back to exit.

### Fixture Hours

Select Fixture Hours, press the ENTER button to confirm, Fixture Hours will show on the display, press the MENU button back to exit.

### Crossload (Software)

Select Crossload (Software), press the ENTER button to confirm, Send will show on the display, press the ENTER button to store. Press the MENU button back to the last menu or let the unit idle one minute to exit menu mode.

---

**NOTE:** Incoming DMX must be removed from the fixture or software crossload will not be activated.

---

### Service

To select Service, press the ENTER button to confirm. Diagnostics will show, press the ENTER button to store. Press the MENU button back to the last menu or let the unit idle one minute to exit menu mode.

**Diagnostics —** To select Diagnostics, press the ENTER button to confirm. Use the UP/DOWN button to select Fan Check, Board Check ,Sensor Check, press the ENTER button to store. Press the MENU button back to the last menu or let the unit idle one minute to exit menu mode.

## MANUAL CONTROL MENU

Enter menu mode, select Manual Control, press the ENTER button to confirm, use the UP/DOWN button to select Red, Green, Blue, Amber, Lime and Cyan. Use the UP/DOWN button to adjust the value from 0 to 255, press the ENTER button to store. Press the MENU button back to the last menu or let the unit idle one minute to exit menu mode.

## COLOR PRESET MENU

### Preset Run

Enter Color Preset mode, select Preset Run, press the ENTER button to confirm, use the UP/DOWN button to select “Select Preset” or Intensity.

### Edit Programs

Enter menu mode, select Edit Programs, press the ENTER button to confirm, MODE will show up, use the UP/DOWN button to select Intensity, Red, Green, Blue, Amber, Lime, Cyan, Store or Clear. Use the UP/DOWN button to adjust the value from 0 to 100%, press the ENTER button to store. Press the MENU button back to the last menu or let the unit idle one minute to exit.

# 3 DMX MAPPING

The fixture can be operated by DMX controller. The following tables assumes a DMX start address of 1. When a different starting address is used, this address becomes channel 1 function and other functions follow in sequence.

**TABLE 2. 16-BIT MODE**

DMX CHANNEL	PARAMETER	DEFAULTS	RANGE DMX	DESCRIPTION
1	Intensity (High)	0	0 - 65535	16bit Intensity (Dimmer) Control
2	Intensity (Low)			0 - 100% Output
3	Strobe	0	0 - 255	Strobe S>>>>>F
			0 - 9	No Strobe Function - Shutter open
			10 - 99	Strobe S>>>>>F
			100 - 109	No Strobe Function - Shutter open
			110 - 179	Lighting Strobe S>>>>>F
			180 - 189	No Strobe Function - Shutter open
			190 - 255	Random Strobe S>>>>>F
4	Fan Control	0	0 - 255	Dynamically control fan speed vs LED Output operation. Control values as follows . . .
			0-4	Automatic fan/output adjustment (Default)
			05 - 255	Linear control of fan speed and LED max output*
				DMX 5 =Highest Constant Fan Speed
				DMX 255 = Lowest Constant Fan Speed
				* Standard mode only
5	Control Channel	0	0 - 255	Control Channel used for full fixture settings, lamp controls, and miscellaneous modes.
				Set discrete value of desired effect, wait >3 seconds, then set value to 0 (Idle).
				**Function does not require 3 Second rule to active, setting output
				to value will automatically activate function
			0 - 5	Idle (Default)
			6 - 10	Full Luminaire ReCal -
				Also Used to Wake fixture up from shutdown
			11 - 15	Fixture Shutdown
			16 - 20	Reserved Values
			21 - 25	Display - Menu ON
			26 - 30	Display - Menu OFF
			31 - 35	Reserved Values
			36 - 40	Reserved Values
			41 - 45	Dimming Curve Linear**
			46 - 50	Dimming Curve S-Curve**
			51 - 55	Dimming Curve Square Law (Default)**
			56 - 60	Reserved
			61 - 65	Dimmer Snap On**
			66 - 70	Dimmer Snap Off (Default)**
			71 - 75	Reserved Values



**TABLE 2. 16-BIT MODE**

DMX CHANNEL	PARAMETER	DEFAULTS	RANGE DMX	DESCRIPTION
			76 - 80	Reserved Values
			81 - 85	Reserved Values
			86 - 90	Reserved Values
			91 - 95	Reserved Values
			96 - 100	Reserved Values
			101 - 105	Reserved Values
			106 - 110	Reserved Values
			111 - 115	Standard Mode - (Default)
			116 - 120	Studio Mode - Reduced output with lower fan settings
			121 - 125	Whisper Mode - Reduced output with lower fan settings
			126 - 130	Reserved Values
			131 - 135	Reserved Values
			136 - 140	Fan On (Default)
			141 - 145	Fan Auto
			146 - 150	Reserved Values
			151 - 155	Reserved Values
			156 - 160	Reserved Values
			161 - 165	Reserved Values
			166 - 170	Reserved Values
			171 - 175	Reset fixture to default
			176 - 255	Reserved Values
6	TW LED High	0	0 - 65535	Tunable LED array 0 - 100%
7	TW LED Low			0 = 4000K
				100% = 6500K

**TABLE 3. 8-BIT MODE**

DMX CHANNEL	PARAMETER	DEFAULTS	RANGE DMX	DESCRIPTION
1	Intensity	0	0 - 255	8 bit Intensity (Dimmer) Control 0 - 100% Output
2	Strobe	0	0 - 255	Strobe S>>>>>F
			0 - 9	No Strobe Function - Shutter open
			10 - 99	Strobe S>>>>>F
			100 - 109	No Strobe Function - Shutter open
			110 - 179	Lighting Strobe S>>>>>F
			180 - 189	No Strobe Function - Shutter open
			190 - 255	Random Strobe S>>>>>F
3	Fan Control	0	0 - 255	Dynamically control fan speed vs LED Output operation. Control values as follows . . .
			0-4	Automatic fan/output adjustment (Default)
			05 - 255	Linear control of fan speed and LED max output*
				DMX 5 =Highest Constant Fan Speed
				DMX 255 = Lowest Constant Fan Speed
				* Standard mode only
4	Control Channel	0	0 - 255	Control Channel used for full fixture settings, lamp controls, and miscellaneous modes. Set discrete value of desired effect, wait >3 seconds,

TABLE 3. 8-BIT MODE

DMX CHANNEL	PARAMETER	DEFAULTS	RANGE DMX	DESCRIPTION
				then set value to 0 (Idle).
				**Function does not require 3 Second rule to active, setting output to value will automatically activate function
			0 - 5	Idle (Default)
			6 - 10	Full Luminaire ReCal - Also Used to Wake fixture up from shutdown
			11 - 15	Fixture Shutdown
			16 - 20	Reserved Values
			21 - 25	Display - Menu ON
			26 - 30	Display - Menu OFF
			31 - 35	Reserved Values
			36 - 40	Reserved Values
			41 - 45	Dimming Curve Linear**
			46 - 50	Dimming Curve S-Curve**
			51 - 55	Dimming Curve Square Law (Default)**
			56 - 60	Reserved
			61 - 65	Dimmer Snap On**
			66 - 70	Dimmer Snap Off (Default)**
			71 - 75	Reserved Values
			76 - 80	Reserved Values
			81 - 85	Reserved Values
			86 - 90	Reserved Values
			91 - 95	Reserved Values
			96 - 100	Reserved Values
			101 - 105	Reserved Values
			106 - 110	Reserved Values
			111 - 115	Standard Mode - (Default)
			116 - 120	Studio Mode - Reduced output with lower fan settings
			121 - 125	Whisper Mode - Reduced output with lower fan settings
			126 - 130	Reserved Values
			131 - 135	Reserved Values
			136 - 140	Fan On (Default)
			141 - 145	Fan Auto
			146 - 150	Reserved Values
			151 - 155	Reserved Values
			156 - 160	Reserved Values
			161 - 165	Reserved Values
			166 - 170	Reserved Values
			171 - 175	Reset fixture to default
			176 - 255	Reserved Values
5	TW LED	0	0 - 255	Tunable LED array 0 - 100%
				0 = 4000K
				100% = 6500K

**TABLE 4. 2 CHANNEL MODE**

DMX CHANNEL	PARAMETER	DEFAULTS	RANGE DMX	DESCRIPTION
1	Intensity	0	0 - 255	8 bit Intensity (Dimmer) Control 0 - 100% Output
2	TW LED	0	0 - 255	Tunable LED array 0 - 100%
				0 = 2700K
				100% = 4500K

**TABLE 5. CONTROL CHANNEL**

RANGE DMX	ITEMS	DESCRIPTION	POWER CYCLE RULES	FUNCTION SELECTION VIA UI
0 - 255	Control Channel	Control Channel used for full fixture settings, lamp controls, and miscellaneous modes. Set discrete value of desired effect, wait >3 seconds, "then set value to 0 (Idle). **Function does not require 3 Second rule to active, setting output to value will automatically activate function "	N/A	N/A
0 - 5	Idle (Default)	Default value used as return point to activate all control functions	N/A	N/A
6 - 10	Full Luminaire ReCal -	Recalibrates all mechanical functions and sensor with in the fixture	N/A	
	Also Used to Wake fixture up from shutdown			
11 - 15	Fixture Shutdown	Shuts down all fixture output and turns off all fans - fixture is activated by power cycle or ReCal command	If fixture is powered down then up fixture will auto wake and not startup in Shutdown Mode	N/A
16 - 20	Reserved Values		N/A	N/A
21 - 25	Display - Menu ON	Switches UI display backlight on remotely - Display will Time out from on after 5 mins	N/A	N/A
26 - 30	Display - Menu OFF		N/A	N/A
31 - 35	Reserved Values		N/A	N/A
36 - 40	Reserved Values		N/A	N/A
41 - 45	Dimming Curve Linear**	Selects Linear Dimming Curve	Holds setting on power cycle	Yes
		Also Used to Wake fixture up from shutdown		
46 - 50	Dimming Curve S-Curve**	Selects S-Law Dimming Curve	Holds setting on power cycle	Yes
51 - 55	Dimming Curve Square Law (Default)**	Selects Square -Law Dimming Curve	Holds setting on power cycle	Yes
56 - 60	Reserved Values			
61 - 65	Dimmer Snap On**	Allows for fastest output changes between levels but reduces smoothness dimming LED	Holds setting on power cycle	Yes
66 - 70	Dimmer Snap Off (Default)**	Ensures all fades between output levels remain smooth and flicker free limits fast instant snaps between levels	Holds setting on power cycle	Yes
71 - 75	Reserved Values		N/A	N/A
76 - 80	Reserved Values		N/A	N/A
81 - 85	Reserved Values		N/A	N/A
86 - 90	Reserved Values		N/A	N/A

**TABLE 5. CONTROL CHANNEL**

RANGE DMX	ITEMS	DESCRIPTION	POWER CYCLE RULES	FUNCTION SELECTION VIA UI
91 - 95	Reserved Values		Holds setting on power cycle	Yes
96 - 100	Reserved Values		Holds setting on power cycle	Yes
101 - 105	Reserved Values		N/A	N/A
106 - 110	Reserved Values	Boost mode - LED output boosted to >120% of standard output fan speeds increased manage heat level of LED (may be limited to only run for XXhrs) NC45 - NC55	N/A	N/A
111 - 115	Standard Mode - Fixture operates at maximum output (Default)	Standard mode - Full LED Output + Full Continuous Fan Spin at top speed (loudest setting) (Fan remain at a constant speed and do not ramp up and down) NC40 *Fans can be switched between On & Auto levels	Holds setting on power cycle	Yes

**TABLE 5. CONTROL CHANNEL**

RANGE DMX	ITEMS	DESCRIPTION	POWER CYCLE RULES	FUNCTION SELECTION VIA UI
116 - 120	Studio Mode - Reduced output with lower fan settings	Studio Mode - Fan speed reduced to appropriate amount to reduce dB levels >10% of full speed + LED @ max output approximately 80% of Standard output at appropriate level to ensure LED work at optimum temperature and output efficiency (fan speed remains at a constant speed and do not ramp up or down) NC35	Holds setting on power cycle	Yes
121 - 125	Whisper Mode - Reduced output with lower fan settings	Silent Mode - ideally Fans do not spin + output capped at appropriate level to ensure LED work at optimum temperature and output efficiency (Fan should never switch on in this mode or change speed if they are on) NC15 target level	Holds setting on power cycle	Yes
126 - 130	Reserved Values		N/A	N/A
131 - 135	Reserved Values		N/A	N/A
136 - 140	Fan On (Default)	Fans run at continuous speed for either standard or studio mode in isolation to the LED operating temperature	Holds setting on power cycle	Yes
141 - 145	Fan Auto	Fans will reduce / increase speed on demand based on LED operating temperature for either standard or studio mode	Holds setting on power cycle	Yes
146 - 150	Reserved Values		N/A	N/A
151 - 155	Reserved		N/A	N/A
156 - 160	Reserved		N/A	N/A
161 - 165	Reserved		N/A	N/A
166 - 170	Reserved		N/A	N/A
171 - 175	Reset fixture to default	Will reset all parameters to default with the exception of the Mx address, fixture mode and Pixel / Zone selection	N/A	Yes - Will reset Dmx address, Mode and pixel group
176 - 255	Reserved		N/A	N/A

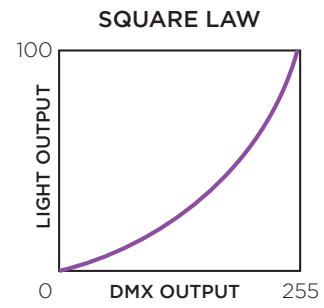
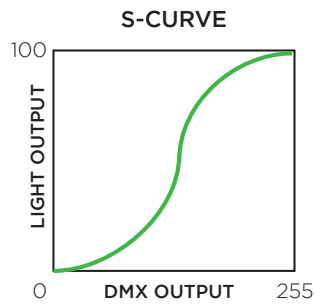
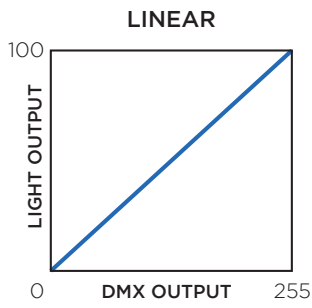

			KNOB 1	KNOB 2	KNOB 3
Full Color	KNOB MODE	MODE	1.DIM 0-100%	2.CCT 4000K-6500K	
Note: Double click Dial 1 to Dial MODE					

## DMX512 CONNECTION

- At last unit, the DMX cable has to be terminated with a terminator. Solder a 120Ω 1/4W resistor between pin 2(DMX-) and pin 3(DMX+) into a 5-pin XLR-plug and plug it in the DMX-output of the last unit.
- Connect the unit together in a `daisy chain` by XLR plug from the output of the unit to the input of the next unit. The cable cannot branched or split to a `Y` cable. DMX 512 is a very high-speed signal. Inadequate or damaged cables, soldered joints or corroded connectors can easily distort the signal and shut down the system.
- The DMX output and input connectors are pass-through to maintain the DMX circuit, when one of the units' power is disconnected.
- Each lighting unit needs to have an address set to receive the data sent by the controller. The address number is between 0-511 (usually 0 & 1 are equal to 1).
- The end of the DMX 512 system should be terminated to reduce signal errors.
- 5 pin XLR: Pin 1: GND, Pin 2: Negative signal (-), Pin 3: Positive signal (+), Pin 4/Pin 5: Not used.

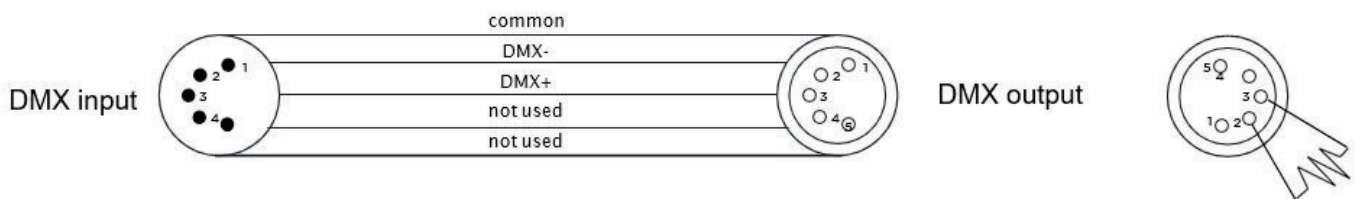
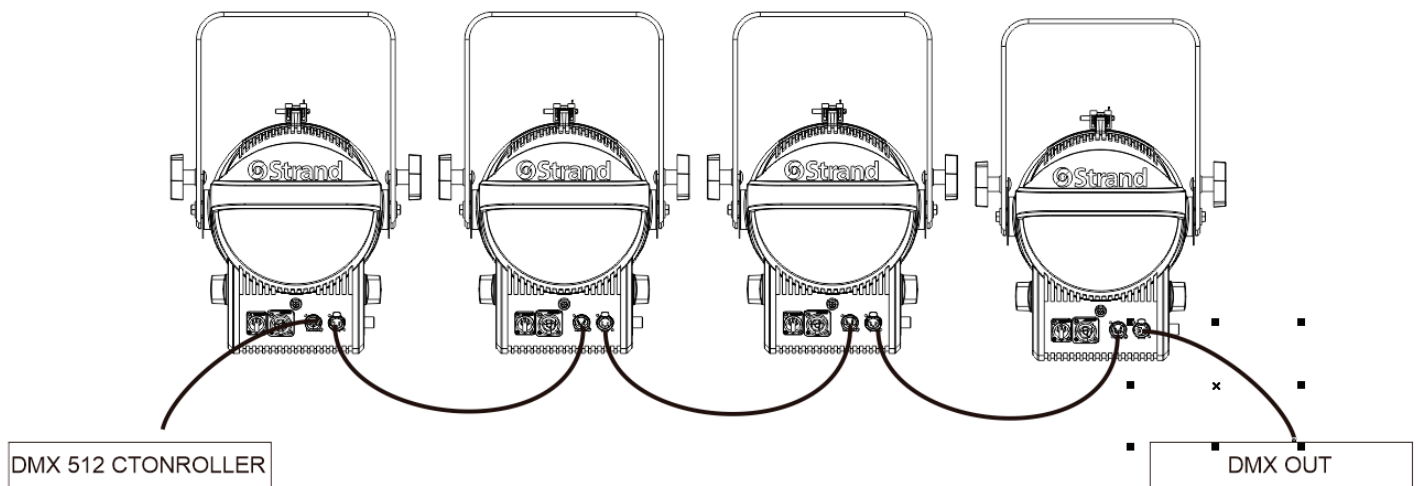

# APPENDIX A

# CARE AND MAINTENANCE

## TROUBLESHOOTING

---

Following are a few common problems that may occur during operation.

### **The unit does not work - light and fan do not turn on**

- Check the connection of power and main fuse.
- Measure the mains voltage on the main connector.

### **Not responding to DMX controller**

- DMX LED should be on. If not, check DMX connectors, cables to see if link properly.
- If the DMX LED is on and no response to the channel, check the address settings and DMX polarity.
- If you have intermittent DMX signal problems, check the pins on connectors or on PCB of the unit or the previous one.
- Try to use another DMX controller.
- Check if the DMX cables run near or run alongside to high voltage cables that may cause damage or interference to DMX interface circuit.

## CLEANING

---

The cleaning of internal must be carried out periodically to optimize light output. Cleaning frequency depends on the environment in which the fixture operates damp, smoky or particularly dirty surrounding can cause greater accumulation of dirt on the fixture's optics.

- Clean with soft cloth using normal glass cleaning fluid.
- Always dry the parts carefully.
- Clean the external optics at least every 30 days.

# ADDENDUM

## Fan Speed and Control

All Vari-lite and Strand lighting luminaires will be governed by the same Fan speed v Noise levels v Maximum power output rules as details below. These noises related to these levels will confirm to Noise Criteria levels details of which are contained within the document.

There are 3 control parameters that can be selected separately or in conjunction when permitted to manage Fan speed v Noise levels v Maximum power output.

**NOTE:** Not all fixture have all modes or functions refer to DMX map and User interface menu tree to see if you product has one of more of these functions.

### Item 1 - Fan 'v' Output Preset Modes

These modes are selectable at either / or the fixtures DMX control channel or via the fixture user interface screen. The section of the modes works in conjunction with Items 3 and will also active or deactivate the Item 2.

**Boost mode** - LED output boosted to >120% of standard output fan speeds increased manage heat level of LED (may be limited to only run for XXhrs). Fixture will not exceed NC45 - NC55 sound levels in this mode

**Standard mode** - Full LED Output + Fan Spin at top speed (loudest setting). Fixture will not exceed NC40 sound levels in this mode

**Studio Mode** - Fan speed reduced to appropriate amount to reduce dB levels >10% of full speed + LED @ max output approximately 80% of Standard output at appropriate level to ensure LED work at optimum temperature and output efficiency (fan speed remains at a constant speed and do not ramp up or down) NC35

**Whisper mode** - Fan speed reduced to appropriate amount to reduce dB levels to >30% of the full speed + LED Max output approximately 60% of Standard output at appropriate level to ensure LED work at optimum temperature and output efficiency (Fan speed remains at a constant speed and do not ramp up or down) NC25

**Silent Mode** - ideally Fans do not spin + output capped at appropriate level to ensure LED work at optimum temperature and output efficiency (Fan should never switch on in this mode or change speed if they on) NC15 target level.

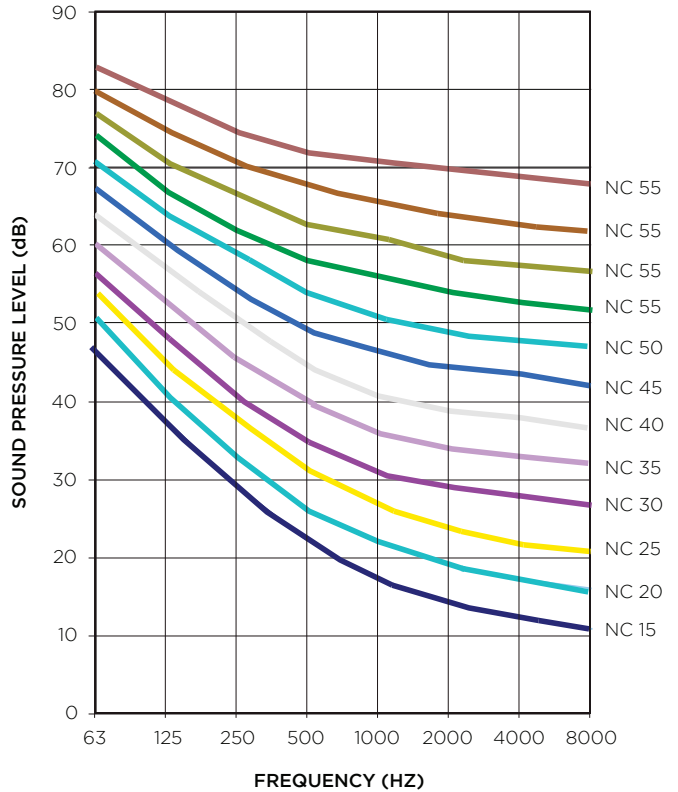

MODE	LED OUTPUT	FAN SPEED	NOISE CRITERION	EQUIVALENT SOUND LEVEL DBA (@3M)
Boost Mode	>100%	Boosted fan speed constant	NC45	50
Standard Mode	Full 100%	Full 100% constant	NC40	45
Studio Mode	80%	Appropriate speed to reduce dB levels >10% of full speed	NC35	40
Whisper Mode	60%	Appropriate speed to reduce dB levels >30% of full speed	NC25	35
Silent Mode	TBC	Fan off	NC15	25

NOISE CRITERION	OCTAVE BAND CENTER FREQUENCY (HZ)							
	63	125	250	500	1000	2000	4000	8000
	SOUND PRESSURE LEVELS (DB)							
NC-15	47	36	29	22	17	14	12	11
NC-20	51	40	33	26	22	19	17	16
NC-25	54	44	37	31	27	24	22	21
NC-30	57	48	41	35	31	29	28	27
NC-35	60	52	45	40	36	34	33	32
NC-40	64	56	50	45	41	39	38	37
NC-45	67	60	54	49	46	44	43	42
NC-50	71	64	58	54	51	49	48	47
NC-55	74	67	62	58	56	54	53	52
NC-60	77	71	67	63	61	59	58	57
NC-65	80	75	71	68	66	64	63	62
NC-70	83	79	75	72	71	70	69	68



## HOW TO OBTAIN WARRANTY SERVICE

---

A copy of the Strand Limited Warranty was included in the shipping package for this Strand product.

To obtain warranty service, please contact customer service at 1-214-647-7880, or [entertainment.service@signify.com](mailto:entertainment.service@signify.com) and request a Return Material Authorization (RMA) for warranty service. You will need to provide the model and serial number of the item being returned, a description of the problem or failure and the name of the registered user or organization. If available, you should have your sales invoice to establish the date of sale as the beginning of the warranty period. Once you obtain the RMA, pack the unit in a secure shipping container or in its original packing box. Be sure to clearly indicate the RMA number on all packing lists, correspondence, and shipping labels. If available, please include a copy of your invoice (as proof of purchase) in the shipping container.

With the RMA number written legibly on or near the shipping address label, return the unit, freight prepaid, to:

Strand  
Attention: Warranty Service (RMA# \_\_\_\_\_)  
10911 Petal Street  
Dallas, Texas 75238  
USA

As stated in the warranty, it is required that the shipment be insured and FOB our service center.

---

**IMPORTANT!** When returning products to Strand for repairs (warranty or out-of--warranty) from a country other than the USA, "Strand Lighting LLC", must appear in the address block as the Importer of Record (IOR) on all shipping documentation, Commercial Invoices, etc. This must be done in order to clear customs in a timely manner and prevent returns.

---

## AMERICAS

10911 Petal Street  
Dallas, TX 75235  
Tel: +1 214-647-7880  
Fax: +1 214-647-8039

## ASIA

Unit C, 14/F, Roxy Industry Centre  
41-49 Kwai Cheong Road  
Kwai Chung, Kwai Tsing  
Hong Kong  
Tel: +852 2796 9786  
Fax: +852 2798 6546

Room 1201, Freetown Tower D  
E 3rd Ring Rd S, 58  
Chaoyang Qu  
Beijing Shi, China  
Tel: +8610-58674776  
Fax: +8610-58674775

B-1-27, Dataran Cascades, No. 13A  
Jalan PJU 5/1  
Kota Damansara PJU 5  
47810 Petaling Jaya  
Selangor, Malaysia  
Tel: +60 3-7611 7302  
Fax: +60 3-7629 4192

## EUROPE

Rondweg Zuid 85  
Winterswijk 7102 JD  
Netherlands  
Tel: +31 543-542516  
Fax: +31 543-542513

24 Sovereign Park  
Coronation Road  
Park Royal, London  
NW10 7QP  
United Kingdom  
Tel: +44 020 8965 3209

## OCEANIA

14H Vega Place  
Rosedale  
Auckland 0632  
New Zealand  
Tel: +64 9-481-0100



©2020 Signify Holding. All rights reserved.

All trademarks are owned by Signify Holding or their respective owners. The information provided herein is subject to change, without notice. Signify does not give any representation or warranty as to the accuracy or completeness of the information included herein and shall not be liable for any action in reliance thereon. The information presented in this document is not intended as any commercial offer and does not form part of any quotation or contract, unless otherwise agreed by Signify. Data subject to change.

CANTATA LED FRESNEL TUNABLE COLD WHITE USER MANUAL

DOCUMENT NUMBER: 64507-001

VERSION DATE: APRIL 27 2020